



Rugged, High-performance Touch Computer.

The ET4255 Industrial Computer delivers ruggedness and the flexibility of a touchscreen in the most demanding of environments. The ET4255 Industrial Computer uses touchscreens which combine exceptional durability with high precision, optical clarity, and brightness. Infra-T and Near Field Imaging (NFI) touch screens can be operated with a bare finger or gloved hand and can withstand severe abuse, abrasions, chemicals, shock, and vibration in wide variations of temperature and humidity.

Offered with the unit are a 15 inch colour TFT display, HDD, 3 x LAN, 2 x USB, 2 x Serial Ports (one required for touchscreen and one required for On Screen Display Control where used) and 1 full length PCI slot for expansion.

Options such as DC power supply, solid state drives and Compact Flash slot help increase this industrial computer's utility into many environments.

Also available is the hazardous location version which will be approved for Class 1, Div 2 locations.

The critical internal components are shock/vibration isolated allowing application to production machinery.

FEATURES

- Sealed to NEMA 4/IP66.
- Mobile Pentium IV, Intel Processor up to 3.06GHz.
- Models with 1 full length PCI slot.
- 15" TFT LCD display offers a +/- 60 degree viewing angle.
- Virtual Keyboard and On Screen Display Control via the touchscreen.
- Touchscreen protected by laminated glass giving exceptional touch durability and flexibility. The touch screen can be operated with gloves and maintains touch accuracy in extreme temperature and humidity variations.
- Excellent shock and vibration characteristics.

"ET4255 - a Industrial Computer for Rugged Conditions"

GENERAL SPECIFICATIONS

DISPLAY:	15" Color TFT, max resolution 1024x768, 16.7 million colors, 230 cd/m ² brightness, active area 304mm x 228mm.
TOUCH SCREEN:	Infra-T infra red options or Near Field Imaging™.
COMPUTER:	Intel Mobile Pentium IV 2.4 GHz processor (minimum), RAM 256Mb standard (upgrade to 2Gb), Embedded Industrial Motherboard with Intel 845 Chipset, 20Gb HDD with shock mounts (base), Solid State Drive 512Mb or 1Gb as an option.
OPERATING SYSTEM:	Windows 2000/Windows NT/Windows XP optional.
INTERFACES:	1 PCI slot, 2 USB ports, 2 Serial ports (1 used by touch screen and 1 by On Screen Display control where used), 3 x 10/100 Base T Ethernet, PS/2 key board and mouse ports.
POWER:	AC power supply, input range 90 to 264 VAC auto-ranging , Frequency 47 to 63Hz, Output power 200 Watts DC power supply, input range 19-32 VDC , Output power 200 Watts optional.
COOLING:	Heatsink.
ENVIRONMENT:	
Operating Shock:	20G, 11mS pulse.
Operating Vibration:	5 – 500Hz, 1G acceleration.
Operating Temperature:	0 to 55°C. (32° – 131°F)
Storage Temperature:	-20 to 60°C. (-4° – 140°F)
Humidity:	95%RH, non-condensing.
ENCLOSURE:	
Enclosure:	Zinc plated and powder coated steel.
Bezel:	Standard — Aluminium. Stainless steel face plate available as an option.
Weight:	17.5Kgs.
Mounting:	Panel mount and VESA mount
OPTIONS:	Stainless steel faceplate, Touch surround keyboard.

DIMENSIONS

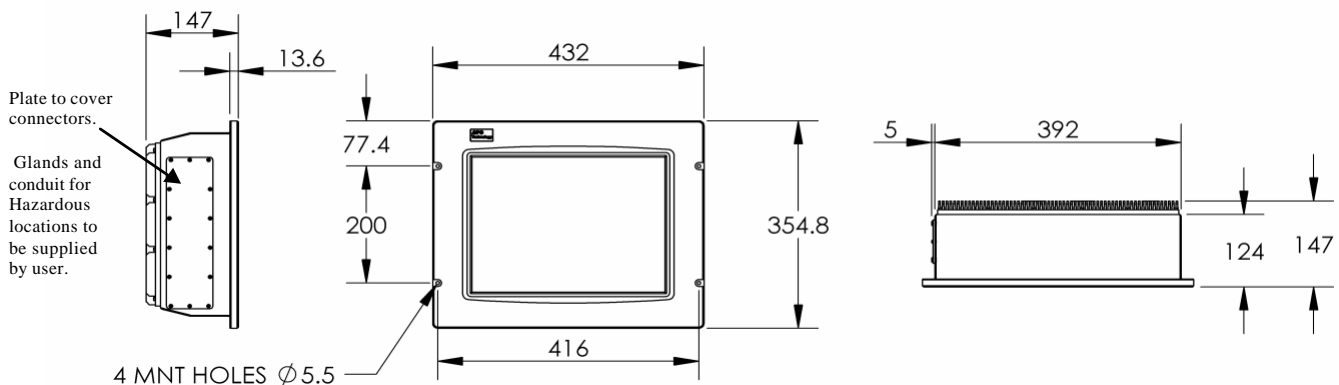

Distributed locally by:
MGR Industries, Inc.
3013 E. Mulberry St.
Ft. Collins, Colorado, USA, 80524
PHONE: 970-221-2201
FAX: 970-484-4078
EMAIL: contact@mgrind.com
WEB: www.mgrind.com

APC Technology
A.B.N. 11 308 986 292
Head Office: 40 Stepney Street, Stepney,
South Australia, 5069
Phone: +61 8 8363 0400
Fax: +61 8 8363 1736
Email: sales@apctechnology.com.au
Web: www.apctechnology.com.au