

The CT2050 rugged flat panel display, a companion product to the CT2250 industrial PC, has a stylish heavy-duty metal and safety glass face plate that is sealed to IP65. The unit is fitted with a 15 inch colour TFT display.

Available as an option is a touch screen either the Infra-T touchscreen, which is suited to gloved-hand operation, or a resistive touch screen.

Being either panel or desk mounted the unit is particularly suited to rugged applications. It is competitively priced and requires little maintenance

One of a range of industrial products the CT2050 is designed and manufactured in Australia by APC Technology, an Australian-owned company with a long history in rugged computer design and manufacture.

FEATURES

- BIG COLOUR DISPLAY
- SEALED FACE PLATE
- LOW MAINTENANCE
- OPTIONAL TOUCHSCREEN
- COMPETITIVE PRICE
- AUSTRALIAN DESIGNED AND MANUFACTURED
- STYLISH AND RUGGED



"CT2050—a Industrial Display for Rugged Conditions"

GENERAL SPECIFICATIONS

POWER:	100 to 240 VAC, 47 to 400 Hz, 30 W max. DC option available.
INTERFACE:	Plug and Play compatible.
DISPLAY:	15" Color TFT, max resolution 1024x768, 250 cd/m ² brightness, active area 304mm x 228mm.
TOUCH SCREEN:	Infra-T infra red or resistive option.
ENVIRONMENT:	
Operating Shock:	10G, 11mS pulse.
Operating Vibration:	5 – 50Hz, 0.1G acceleration
Operating Temperature:	5° to 50°C.
Storage Temperature:	0 to 60°C.
Humidity:	50°C (122°F, 85% non-condensing)
SEALING:	Front Face sealed to IP65.
CONSTRUCTION:	Zinc plated and powder coated steel. Stainless steel face plate available as an option.
CONFIGURATION:	The CT2050 is available with the option of a touch screen, APC Technology's own Infra-T or a resistive touch screen.

DIMENSIONS

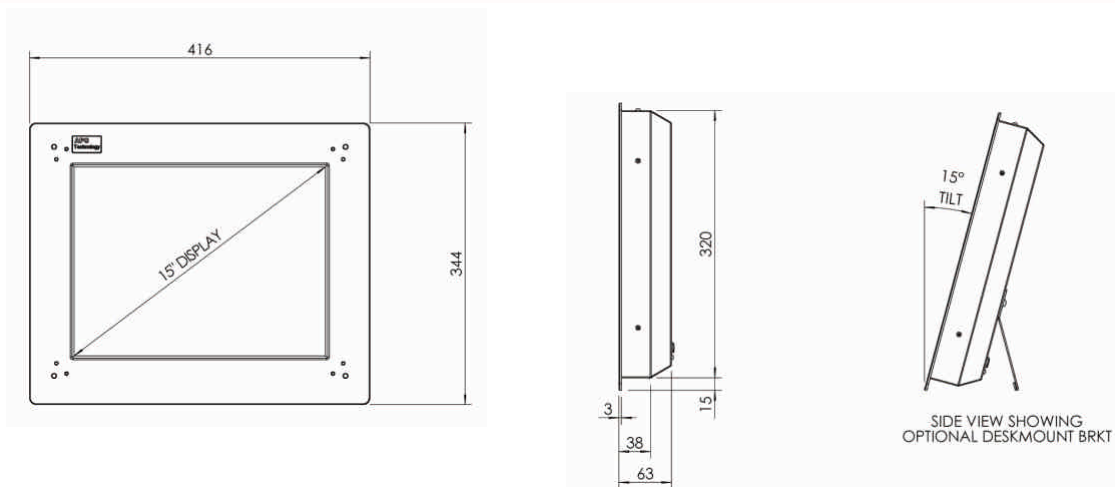

Distributed locally by:
MGR Industries, Inc.
3013 E. Mulberry St.
Ft. Collins, Colorado, USA, 80524
PHONE: 970-221-2201
FAX: 970-484-4078
EMAIL: contact@mgrind.com
WEB: www.mgrind.com

APC Technology
HEAD OFFICE: 40 STEPNEY
STREET,
STEPNEY, SOUTH AUSTRALIA,
5069
PHONE: +61 8 8363 0400
FAX: +61 8 8363 1736
EMAIL: sales@apctechnology.com.au
WEB: www.apctechnology.com.au